

Class 125 • Bolted Bonnet • N-R Stem • Bronze Trim • Flanged

G-612-I International Iron Gate Valve

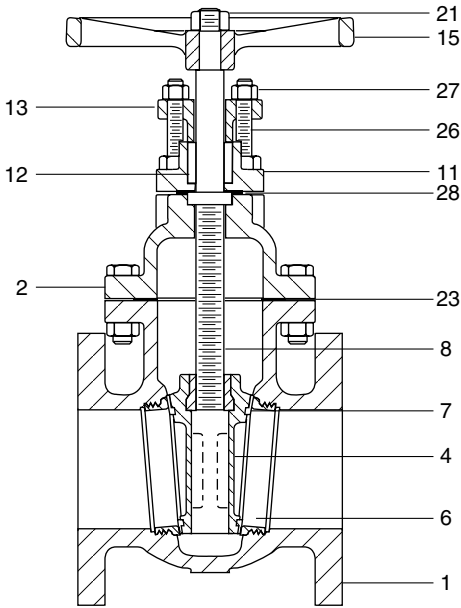

Materials of Construction

No.	Description	Material	ASTM
1	Body	Cast Iron	A126 Class B
2	Bonnet	Cast Iron	A126 Class B
4	Disc	Bronze (2" - 3")	B584 C84400
		Cast Iron (4" - 12")	A126 Class B
6	Seat Ring	Bronze	B584 C84400
7	Disc Ring	Bronze (4" - 12")	B584 C84400
8	Stem	Manganese Bronze	B584 C86400
11	Stuffing Box	Ductile Iron (2" - 8")	A536 Gr. 65-45-12
		Cast Iron (10" - 12")	A126 Class B
12	Packing	Braided Flexible Graphite with Corrosion Inhibitor	
13	Gland Flange	Ductile Iron (2" - 8")	A536 Gr. 65-45-12
14	Gland*	Bronze (10" - 12")	B584 C84400
15	Handwheel	Ductile Iron	A536 Gr. 65-45-12
21	Handwheel Nut	Carbon Steel	A563 Gr. A
23	Bonnet Gasket	Aramid Fibers with SBR Binder	
24	Bonnet Bolt	Carbon Steel	A307 Gr. B
25	Bonnet Bolt Nut	Carbon Steel	A563 Gr. A
26	Gland Bolt	Carbon Steel	A307 Gr. B
27	Gland Bolt Nut	Carbon Steel Zinc-Plated	A563 Gr. A
28	Stuffing Box Gasket	Aramid Fibers with SBR Binder	
34	Stuffing Box Bolt*	Carbon Steel	A307 Gr. B
35	Stuffing Box Bolt Nut*	Carbon Steel	A563 Gr. A
55	Gland Follower*	Ductile Iron (10" - 12")	A536 Gr. 65-45-12

* Not shown

See page 5 for Pressure Temperature Ratings

Dimensions and Weights Inches (millimeters) - Pounds (kilograms)

Valve Size	Dimensions			WT
	B	C	M	
2	11.31	8.00	7.00	30
	(287)	(203)	(178)	(14)
2 ½	12.40	8.00	7.50	40
	(315)	(203)	(191)	(18)
3	13.25	8.00	8.00	56
	(337)	(203)	(203)	(25)
4	16.31	10.00	9.00	90
	(414)	(254)	(229)	(41)
5	18.00	10.00	10.00	126
	(457)	(254)	(254)	(57)
6	20.69	12.00	10.50	152
	(526)	(305)	(267)	(68)
8	24.12	14.00	11.50	260
	(613)	(356)	(292)	(117)
10	32.25	16.00	13.00	484
	(819)	(406)	(330)	(220)
12	36.00	18.00	14.00	685
	(914)	(457)	(356)	(311)

Industry Standards
MSS SP-70, Type 1

